

---

**User's  
Manual**

**8-CH, 100 kS/s Isolated Digitizer  
Module**

**WE7273**

---

---

Thank you for purchasing the 8-CH, 100 kS/s Isolated Digitizer Module WE7273 for the PC-based measurement instruments, WE7000.

This User's Manual contains useful information about the function, connection to the measuring station, and troubleshooting of the WE7273. This manual assumes that you will be using the WE7000 Control Software that is included with the measuring station.

For general information about the WE7000 (primarily the operations of the measuring station, the optical interface module, the optical interface card, and the WE7000 Control Software) see the following manual that is included with the measuring station.

Manual Title	Manual No.
WE7000 User's Manual	IM707001-01E

To ensure correct use, please read this manual thoroughly before operation. Keep this manual in a safe place for quick reference in the event a question arises.

## Notes

- **The contents of this manual describe WE7000 Control Software Ver. 4.6.4.0 and module software Ver 3.01. If you are using another version of the software, the operating procedures or the figures given in this manual may differ from the actual software.**
- The contents of this manual are subject to change without prior notice as a result of continuing improvements to the instrument's performance and functions.
- Every effort has been made in the preparation of this manual to ensure the accuracy of its contents. However, should you have any questions or find any errors, please contact your nearest YOKOGAWA dealer.
- Copying or reproducing any or all of the contents of this manual without YOKOGAWA's permission is strictly prohibited.

## Trademarks

- Microsoft, Windows, and Windows NT are either registered trademarks or trademarks of Microsoft Corporation in the United States and/or other countries.
- Adobe and Acrobat are trademarks of Adobe Systems Incorporated.
- Other product names are trademarks or registered trademarks of their respective holders.

## Revisions

1st Edition: January 2004

# Checking the Contents of the Package

Unpack the box and check the contents before operating the instrument. If the contents are not correct or missing or if there is physical damage, contact the dealer from which you purchased them.

## Measurement Module

Check that the model name given on the name plate matches those on the order.

### MODEL

Model	Suffix Code	Description
707273		WE7273 8-CH, 100 kS/s Isolated Digitizer Module
	/HE	English help message

### NO.

When contacting the dealer from which you purchased the instrument, please quote the instrument No.

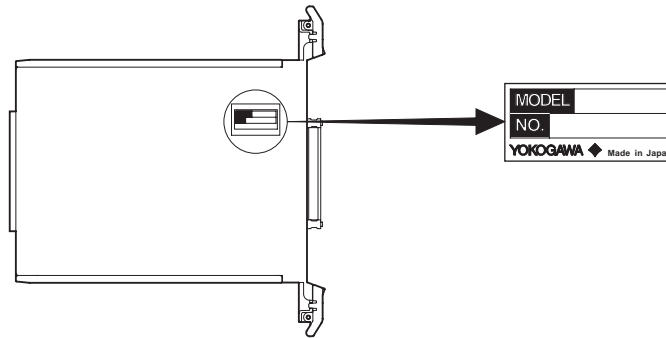

## Standard Accessories

The following standard accessories are supplied with the instrument. Make sure that all items are present and undamaged.

User's Manual (1)  
IM707273-01E

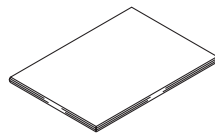

Terminal block (attached to the module)  
B9953FE  
(Connected to the module.)

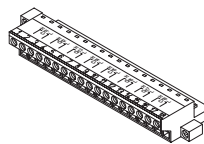

## Optional Accessories (Sold Separately)

Name	Model	Description
Terminal block	B9953FE	Clamp type terminal, sold in units of 1 piece

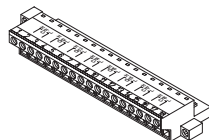

# How to Use This Manual

## Structure of the Manual

This User's Manual consists of the following four chapters and an index.

Chapter	Title	Description
1	<b>Explanation of Functions</b>	Explains the system configuration and functions.
2	<b>Hardware Preparation</b>	Explains how to install the module into the measuring station and how to connect the input.
3	<b>Troubleshooting and Maintenance</b>	Explains the procedures for troubleshooting and self testing.
4	<b>Specifications</b>	Explains the specifications of the module.
<b>Index</b>		Index of contents.

## Conventions Used in This Manual

### Unit

k ..... Denotes 1000. Example: 100 kHz

K ..... Denotes 1024. Example: 720 KB

### Displayed characters

Alphanumeric characters enclosed with [ ] usually refer to characters or settings that are displayed on the screen.

### Symbols

The following symbol marks are used to attract the operator's attention.



Affixed to the instrument. Indicates danger to personnel or to the instrument. The operator must refer to the User's Manual. The symbol is used in the User's Manual to indicate the reference.

### **WARNING**

Describes precautions that should be observed to prevent injury or death to the user.

### **CAUTION**

Describes precautions that should be observed to prevent minor or moderate injury, or damage to the instrument.

### **Note**

Provides information that is important for operating the instrument properly.



# Contents

<b>Checking the Contents of the Package</b> .....	2
<b>How to Use This Manual</b> .....	3
<b>Chapter 1 Explanation of Functions</b>	
1.1 System Configuration and Block Diagram .....	1-1
1.2 Operation Panel .....	1-2
1.3 Setting the Conditions for Acquiring the Waveform .....	1-3
1.4 Setting the Trigger .....	1-7
1.5 Automatic Saving of the Waveform Data, File File Conversion, and Other Settings .....	1-8
1.6 Synchronizing to Other Modules Using the Bus Trigger/Time Base Signal .....	1-10
1.7 Names and Functions of Sections .....	1-12
<b>Chapter 2 Hardware Preparation</b>	
△ 2.1 Installing the Module into the Measuring Station .....	2-1
△ 2.2 Connecting the Input Signal Wire .....	2-3
<b>Chapter 3 Troubleshooting and Maintenance</b>	
3.1 Troubleshooting .....	3-1
3.2 Self Test .....	3-2
3.3 Maintenance .....	3-3
<b>Chapter 4 Specifications</b>	
4.1 Performance Specifications .....	4-1
4.2 Default Values (Factory Default Settings) .....	4-3
4.3 General Specifications .....	4-4
4.4 Dimensional Drawings .....	4-6
<b>Index</b>	

1

2

3

4

Index

# 1.1 System Configuration and Block Diagram

## System Configuration

The following is an example in which the 8-CH, 100 kS/s Isolated Digitizer Module WE7273 is installed into the measuring station and the measuring station is connected to the PC with the optical fiber cable.

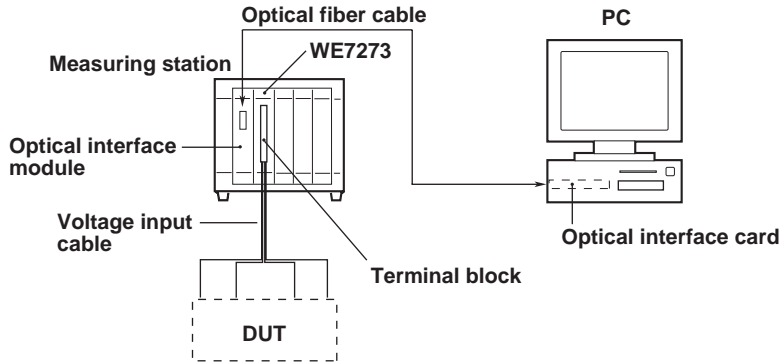

## Block Diagram

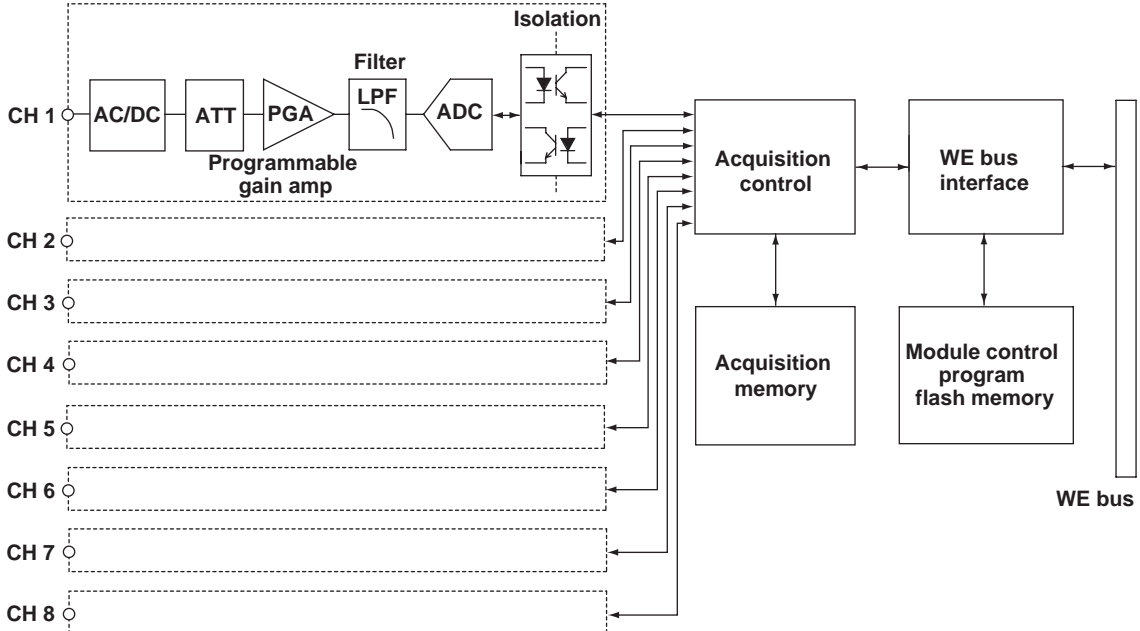

### Description of operation

The signal input terminals of the digitizer module are insulated from the ground potential. In addition, the channels are isolated from each other allowing voltage signals of different electric potential to be measured simultaneously.

There are eight signal input channels operating under the same sampling clock.

The voltage input signal is applied to the module terminal board through the accessory clamp terminal. The voltage signal applied to the input terminal of each channel (CH1 to CH8) passes through an AC/DC coupling circuit and an attenuator and enters the programmable gain amplifier. The voltage amplitude of each input signal is adjusted by the programmable amplifier. Then, the signal passes through the low-pass filter (LPF) and enters the A/D converter (ADC). At the A/D converter, the input signal is sampled by synchronizing to the clock signal provided by the time base, and converted to digital data. The digital data is then isolated by the photo coupler, retrieved by the acquisition control circuit, and stored in the acquisition memory according to the settings such as the sampling interval and the trigger condition.

The data in the acquisition memory can be read from the PC through the communication interface.

## 1.2 Operation Panel

The WE7000 Control Software that is installed in the PC is used to control the 8-CH, 100 kS/s Isolated Digitizer Module WE7273. The WE7000 Control Software displays operation panels similar to those shown in the figure below. This User's Manual does not explain the operations of the operation panel or waveform monitor. For the operations of these items, see the on-line help that is provided with the WE7000 Control Software.

### Setting the conditions for acquiring the waveform

Turn measurement ON/OFF  
 Select measurement range  
 Select measurement range  
 Set the input filter

Start/stop measurement  
 Turn waveform monitor ON/OFF  
 Check during continuous measurements (only during trigger mode)  
 Select acquisition method  
 Set sampling interval  
 Select number of memory partitions  
 Set the record length  
 Number of acquisitions (number of memory blocks used)

### Selecting the number of measurement channels and the time base

Trig tab

Select time base  
 Select the number of measurement channels

### Setting the trigger

Select the trigger type  
 Set the trigger level

Trig tab  
 Select trigger source

Select trigger combination  
 Set pretrigger  
 Set trigger hold off  
 Overlap acquisition enabled



## 1.3 Setting the Conditions for Acquiring the Waveform

### Turning ON/OFF the Measurement Channel

Measurements are made only on the channels that have the [On] check box selected. If [1CH], [2CH] or [4CH] is selected in [Selecting the number of measurement channels] as described later, then you can only check up to that amount.

### Input Coupling

Select which component of the input signal is to be acquired.

AC: Acquire only the AC component of the input signal.

DC: Acquires all the components (DC and AC) of the input signal.

### Measurement Range (Range)

You can select from the following measurement ranges.

Setting	Measurement Range (Accuracy Guaranteed Measurement Range)
50 mV	-50 mV to 50 mV
100 mV	-100 mV to 100 mV
200 mV	-200 mV to 200 mV
500 mV	-500 mV to 500 mV
1 V	-1 V to 1 V
2 V	-2 V to 2 V
5 V	-5 V to 5 V
10 V	-10 V to 10 V
20 V	-20 V to 20 V
50 V	-50 V to 50 V

### Acquisition Method (Acquisition Mode)

Select the measurement data acquisition method from the following four modes.

#### Trigger mode (Triggered)

The measurement data are acquired to the acquisition memory according to the specified trigger condition (see section 1.4). After acquiring the specified record length of data, the operation stops. In this mode, the acquisition memory can be partitioned and the measured data can be acquired to these individual memory blocks each time triggering occurs. If the [Repeat] check box\* is selected, the operation repeats until the next time the [Start] button is clicked.

\* [Repeat] check box appears only when the expression “optimal number of memory partitions  $\geq 2 \times$  number of acquisition” is satisfied. The “optimal number of memory partitions” refers to the number of partitions that is used as a matter of convenience inside the module. In some cases, the memory can be partitioned into smaller sections depending on the record length and the number of channels. In such cases, the maximum possible number of partitions is determined, and this value is taken to be the “optimal number of memory partitions.”

The optimal number of memory partitions is the largest value of  $2^n$  which is smaller than “ $8,388,608 / (\text{the number of channels specified for the channel mode} \times \text{the record length})$ .” For example, if the channel mode is 4CH and the record length is 10000, the calculation is  $8,388,608 / (4 \times 10000)$  which is approximately 210. In this case, the optimal number of partitions is 128. Thus, if the number of acquisitions is less than or equal to 64, the [Repeat] check box appears. If it is larger than 64, the check box does not appear. If the optimal value exceeds “256,” the number of partitions is set to “256.” Note that if the number of acquisitions is set to “0,” then the [Repeat] check box does not appear.

#### Free run mode (Free Run)

Acquisition of the measured data starts immediately upon starting the measurement. The acquisition stops when the measurement is stopped.

### 1.3 Setting the Conditions for Acquiring the Waveform

#### Gate (level) mode (Gate(Level))

The measurement data are acquired during the time when the specified trigger condition is satisfied (gate period). If the specified record length of data is acquired before the gate period ends, the acquisition stops at that point. The operation repeats the number of times specified by the number of acquisitions. If you stop the measurement before this number is reached, the acquisition stops immediately.

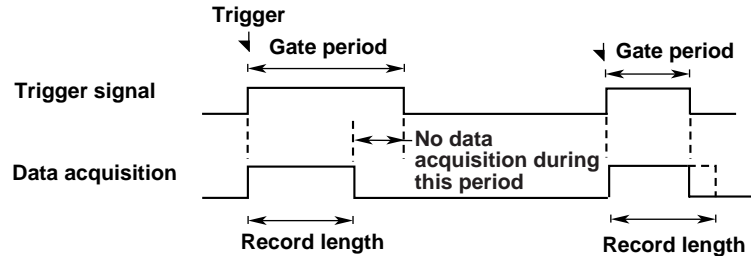

#### Gate (edge) mode (Gate(Edge))

Data acquisition starts when the specified trigger condition is satisfied and pauses when the trigger condition is no longer satisfied. When the trigger condition is satisfied again, data acquisition starts at a new memory block. The operation repeats the number of times specified by the number of acquisitions. If you stop the measurement before this number is reached, the acquisition stops immediately.

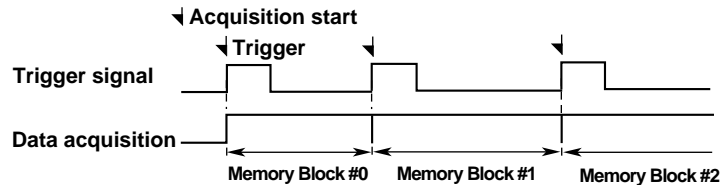

### Sampling Interval

#### During trigger/gate mode

You can select the sampling interval in the range from 10  $\mu$ s to 10 s (in 1  $\mu$ s steps).

#### During free run mode

You can select the sampling interval in the range from 1 ms to 10 s (in 1  $\mu$ s steps).

### Memory Partition (Valid Only during Trigger Mode)

During the trigger mode, you can divide the acquisition memory into multiple blocks and acquire the data to the memory blocks in order every time the trigger occurs. You can divide the memory into 1/2/4/8/16/32/64/128/256 partitions. When using memory partitions, if the measurement is stopped before reaching the number of acquisitions, the data in the memory block that was being written at that time are invalid.

### Record Length (Valid Only during Trigger/Gate (Level) Mode)

Enter the value in the [Record Length] entry box. The selectable range during the trigger mode is “2 to 8 M/number of memory partitions,” “2 to 4 M/number of memory partitions,” “2 to 2 M/number of memory partitions,” and “2 to 1 M/number of memory partitions” when the number of measurement channels is 1, 2, 3 or 4, and 5 to 8, respectively. If you specify “0” in the trigger mode, the record length is set to “maximum selectable record length/number of memory partitions.”

In the gate (level) mode, the range is “2 to maximum record length.” If you specify “0” in the gate (level) mode, the record length is set to “maximum record length.” In this case, the memory is partitioned depending on whether or not the trigger conditions are satisfied. The maximum number of memory blocks that can be created is 256.

The selectable minimum record length is set so that “record length  $\times$  sampling interval” is greater than or equal to 5 ms. If an internal clock is used as the time base, this limitation takes effect. If a value smaller than the minimum record length is specified, it is set to the minimum record length. When an external clock is used, however, this limitation does not take effect. In this case, the range is set to the specified value, but if “record length  $\times$  sampling interval” becomes less than 5 ms, measurements may fail to operate correctly.

### Number of Acquisitions (No. of Acquisitions) (Valid Only during Trigger/Gate Mode)

You can specify the number of times to acquire the data when using the trigger or gate mode. The setting range is from 1 to 32,768 times. However, if the specified record length is greater than or equal to (the maximum record length/2), you can only specify one for the number of acquisitions. If you select “0,” the acquisition of data continues until the measurement is stopped or the specified record length of data is acquired. After acquiring the number of acquisitions of data or if the acquisition is stopped, the waveform of the measured data is displayed. For example, if you set the number of acquisitions to “3” in the trigger mode, the module operates as follows.

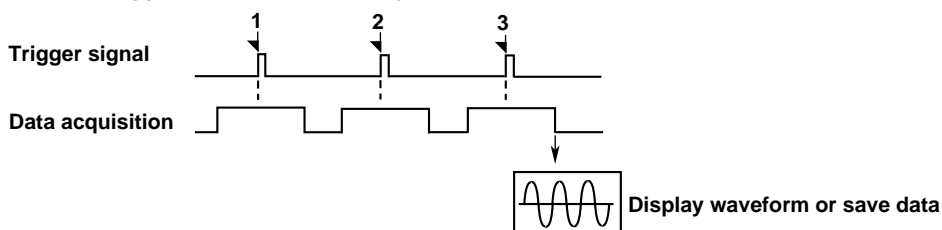

If you set a number less than the number of memory partitions in the trigger mode, you will have to specify the number of memory blocks to use. If you set a number larger than the number of memory partitions, the data are acquired until the specified number is reached or until the specified record length is reached. In the gate mode, measured data are acquired by taking the specified record length to be one block. When the specified record length is equal to or less than “the maximum record length/256” and the number of acquisitions is set to 256 or less, all of the acquired data are saved. But, if the number of acquisition is set above 256, the acquired data beyond the 256th acquisition overwrites the previous data starting from the first acquisition. If the record length is set above “maximum record length/256” points, the data are overwritten when the number of acquisitions exceeds (maximum record length/specified record length).

## 1.3 Setting the Conditions for Acquiring the Waveform

---

### **Note**

- If the number of acquisitions is greater than the number of memory partitions in the trigger mode, only the last “number of memory partitions” blocks of measured data are saved. In addition, you can only specify “1” for the number of acquisitions if the number of memory partitions is set to “1.”
  - If (number of acquisitions × record length × number of measurement channels\*) is “8M” points or less, and the number of acquisitions exceeds 256, then only the last 255 blocks of measured data are saved. If (number of acquisitions × record length × number of measurement channels\*) exceeds “8M” points, only the last “8M/(record length × number of measurement channels)” blocks of measured data are saved. (\*If the number of measurement channels is “3” and “5” to “7” it is considered to be “4,” and “8.”)
  - If the specified record length is greater than or equal to (maximum record length/2) in the gate mode, you can only specify “1” for the number of acquisitions.
- 

### **Number of Measurement Channels (CH Mode)**

The maximum record length can be changed by limiting the number of measurement channels. The available settings are: 8 channels (no limit), 4 channels, 2 channels, and 1 channel. The maximum record length becomes 1 Mword for 8 channels, 2 Mword for 4 channels, 4 Mword for 2 channels, and 8 Mword for 1 channel.

### **Time Base**

You can select whether to sample the input signal using the sampling interval that is based on the module’s internal clock (Internal) or the time base signal [CMNCLK]\* of the measuring station (BUSCLK setting).

- \* For setting procedures, see section 4.6, “Setting the Trigger Source/Time Base/Arming” in the WE7000 User’s Manual (IM707001-01E).

### **Turning ON/OFF the Input Filter (Filter 1 kHz)**

High frequency noise can be eliminated from the input signal. Select 5 kHz, 500 kHz, 50 Hz, or Off.

## 1.4 Setting the Trigger

### Trigger Source (Source)

Select the signal for triggering. The choices are shown below.

Internal : Input signal (includes input signals from 8-CH, 100 kS/s Isolated Digitizer Modules that are linked)

BUSTRG: Bus signal (BUSTRG1/(BUSTRG2) of the WE bus

### Trigger Type and Trigger slope (Trig Type)

When the trigger source is set to the input signal, you can select the trigger type from the following list of choices. Select [Off] if you do not want it to be a trigger source.

#### Rise/Fall/Both (Edge trigger)

With this setting, the trigger occurs when the input signal changes from below the trigger level to above the trigger level (Rise) or from above the trigger level to below the trigger level (Fall). You can have the trigger occur on the rise or fall or both.

#### High/Low (State trigger)

With this setting, the trigger occurs when the input signal is above the specified trigger level (high) or below the trigger (Low) or when it enters the high or low condition.

### Trigger Level (Trig Level)

The selectable range of voltage is the measurable range determined by the measurement range. It is set for each channel. The resolution is 0.1 mV for measurement range of  $\pm 50$  mv, 1 mV for measurement range of  $\pm 100/200/500$  mv, 10 mV for measurement ranges of  $\pm 1/2/5$  V and 100 mV for measurement ranges of  $\pm 10/20/50$  V.

### Trigger Combination (Combination)

Select one from the following list of choices.

#### OR trigger

The trigger occurs if any one of the trigger conditions specified for the input signal of each channel is satisfied.

#### AND trigger

The trigger occurs when all of the trigger conditions specified for the input signal of each channel are satisfied.

### Pretrigger

You can acquire the measured data before the trigger point into the acquisition memory. Set how many points before the trigger point to begin the acquisition in the range, "1 to (specified record length - 2)."

### Trigger Hold Off (Valid Only during Trigger Mode) and Overlap Acquisition Permission

Select the trigger hold-off period that is used to temporarily stop the detection of the next trigger once a trigger occurs. With the factory default settings, the detection of the next trigger does not occur until the measured data are stored in the acquisition memory (overlap acquisition disabled). Therefore, the hold-off period can be set in the range "record length to 8,388,608." By enabling overlap acquisition, the hold-off period can be set in the range "1 to 8,388,608." In some cases, the measurement stops when the trigger hold off is set to 1/255 of the record length or less. In this case, set the value above 1/255 of the record length.

## 1.5 Automatic Saving of the Waveform Data, File File Conversion, and Other Settings

The following functions are functions of the WE7000 Control Software.

For the operations of the following functions, see the on-line help that is provided with the WE7000 control Software.

### Displaying the Waveform

The waveform is displayed in the waveform monitor of the WE7000 Control Software.

### Automatic Saving of Waveform Data

Besides saving the data displayed on the waveform monitor, you can also have the waveform data automatically saved using a trigger or save the data continuously in free run mode.

#### During trigger/gate mode

There are two methods of saving the data.

- Cyclic

You specify the number of files and the data are saved in a cyclic pattern within the specified number of files until the measurement is stopped. The newest data is not the file with the largest file number, but the file to which the data were saved immediately before stopping the measurement.

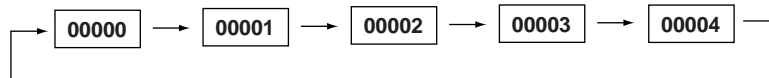

- File number limit

You specify the number of files and the data are saved up to the specified number and then the operation stops.

#### During free run mode

You can select to save the data to one file or to multiple files by specifying the number of data points.

### Converting the Waveform Data

Waveform data that are saved can be converted to ASCII data in CSV format (\*.csv) or to a physical value in 32-bit floating point format (conforming to IEEE754-1985) (\*.wvf).

This file conversion can also be performed on data saved with the waveform monitor.

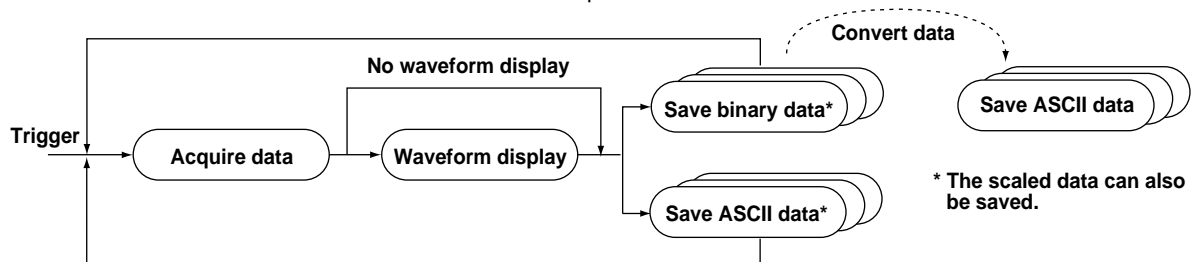

### Scaling the Measured Data

Set the measured values at any two points (VP1 and VP2) and their corresponding physical values (SP1 and SP2). The values at these four points define the scale conversion equation ( $Y=ax+b$ ). The measured values are converted to physical values according to this equation, and the waveform display and saving operations are carried out.

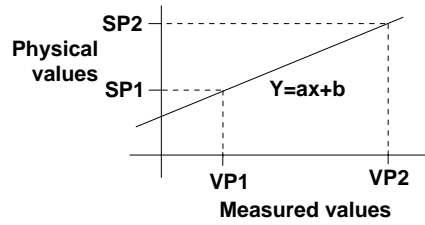

## 1.6 Synchronizing to Other Modules Using the Bus Trigger/Time Base Signal

### Input/Output of Bus Trigger Signals

The 8-CH, 100 kS/s Isolated Digitizer Module WE7273 can output bus trigger signals based on the results of comparing the input signal with the threshold (see 1.4, “Setting the Trigger” for details on how to set the trigger). Because the comparison between the input signal and the threshold is done in sync with the time base signal, the bus trigger signal changes in sync with the time base signal and “True” is output during the time the trigger conditions are satisfied.

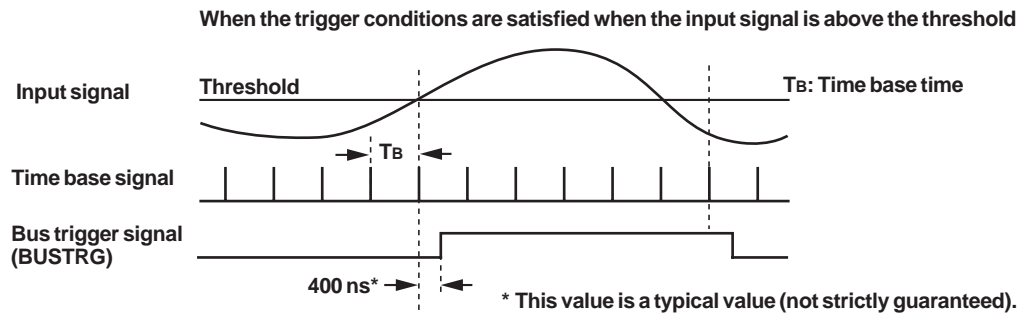

The WE7273 can also acquire data by following the bus trigger signal. If the bus trigger signal becomes “True” between the “False” to “True” edge and the “True” to “False” edge of the time base signal, then the trigger is considered to have been satisfied by the data sampled with the time base signal. Note the following when making multiple acquisitions in the trigger mode. Because the bus trigger signal is detected on the level of the signal, if the duration in which the bus trigger signal remains “True” is longer than the hold off period, the next acquisition starts after the hold off period.

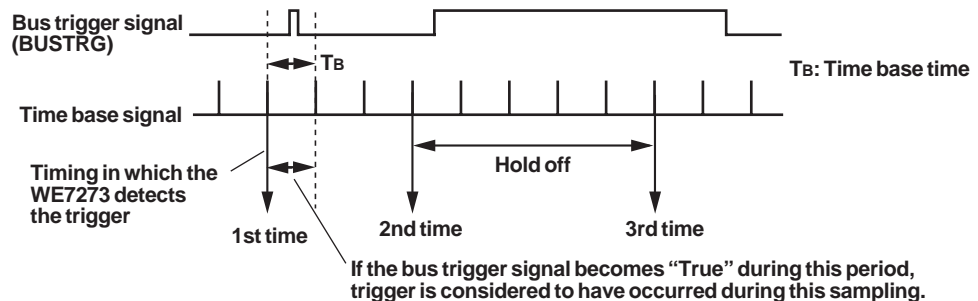

In addition, the WE7273 can output a bus trigger signal upon detecting a trigger within the module, and receive the results of the AND/OR computation on the bus to trigger the actual trigger operation.

### Input/Output of Time Base Signals

While the data acquisition is in progress, the time base signal generated by the internal clock of the WE7273 can be output to the time base signal bus (CMNCLK) in the measuring station. The time difference between the internal clock and the time base signal (CMNCLK) is approximately 100 ns (typical value\*). Conversely, the WE7273 can input and synchronize to the time base signal (CMNCLK) on the bus in order to sample the input signal. If the period of the time base signal is shorter than the setting range of the sampling interval (see 1.3, “Setting the Conditions for Acquiring the Waveform”), the time base signal is sometimes ignored and the sampling does not occur. The delay from the time the time base signal enters the WE7273 to the time the sampling starts is approximately 80 ns (typical value\*).

\* Typical value represents a typical or average value. It is not strictly guaranteed.



### Controlling the Timing of the Start of the Measurement (Arming)

When the arming signal bus (ARM) is connected to the measurement module in the trigger source/time base source setting dialog box, clicking the [Start] button on the operation panel causes the module to enter the arming signal wait state. The measurement starts when the arming signal becomes [True]. If [Repeat] check box of the [Start] button is selected, the module enters the arming signal wait state after each measurement. When the arming signal becomes [True] again, the module acquires the next waveform.



## 2.1 Installing the Module into the Measuring Station

### Preparing to Install the Module

The measuring station comes with each slot covered with a cover plate as shown in the figure below. Verify that the power supply is not connected to the measuring station, then loosen the module attachment screws (2 locations) and remove the cover plate from the slot where the module is going to be installed. Please note that the slot on the left end is dedicated to the communication module and therefore this module cannot be installed there.

\* The following figure shows an example of the measuring station WE400.

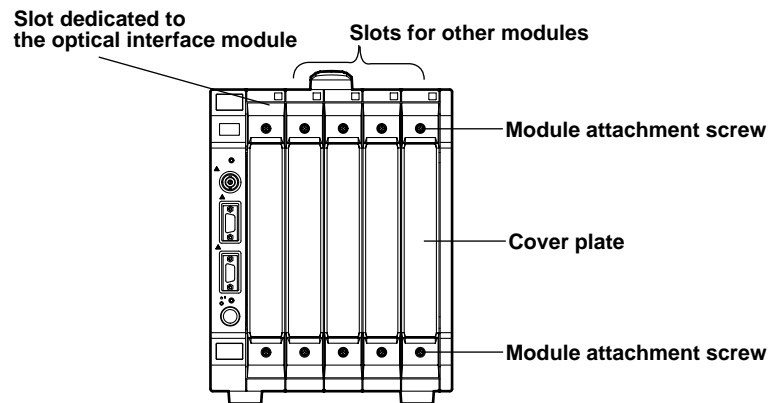

### Installing the Digitizer Module



#### WARNING

- Make sure to fasten the top and bottom attachment screws. If you connect the input signal cable without fastening the attachment screws, the protective grounding of the Measurement module provided by the power cord is compromised and may cause electric shock.



#### CAUTION

- To avoid damaging the instrument when installing modules, make sure to turn OFF the standby power switch of the measuring station.
- Be careful not to get your fingers caught in the ejection lever when inserting the module. In addition, do not put your hand inside the slot, because there are protrusions along the module guide that may injure your fingers.
- Do not remove the cover plates from unused slots. It can cause overheating and malfunction. The cover plates are also needed to minimize the influence of electromagnetic interference.

Insert the module along the guide rail of the slot from which you removed the cover plate. Insert the module until it clicks into the connector. Be careful not to get your fingers caught in the ejection lever while inserting the module.

When the module is securely inserted, fasten the module attachment screws (tightening torque: 0.6 to 0.7 N-m).

To remove the module, loosen the module attachment screws and pull the ejection lever from the inside to the outside. This will force the module out of the slot.

<There is an illustration on the next page.>

## 2.1 Installing the Module into the Measuring Station

---

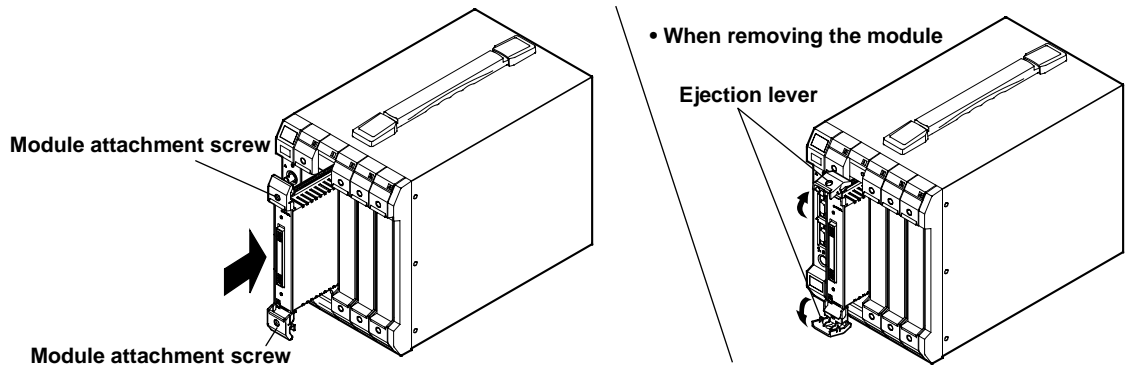

---

### **Note**

When synchronizing multiple isolated digitizer modules for measurement (module linking), install them in adjacent slots.

---

## 2.2 Connecting the Input Signal Wire

The input signal wires are connected to the terminal block of the digitizer module.

### Terminal block

The input terminals are clamp type terminals. The terminal arrangement is as follows:

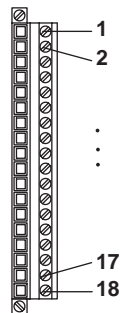

Terminal No.	Signal Name	Terminal No.	Signal Name
1	N.C. (No connection)	11	CH 5 L (CH 5 negative)
2	CH 1 H (CH 1 positive)	12	CH 6 H (CH 6 positive)
3	CH 1 L (CH 1 negative)	13	CH 6 L (CH 6 negative)
4	CH 2 H (CH 2 positive)	14	CH 7 H (CH 7 positive)
5	CH 2 L (CH 2 negative)	15	CH 7 L (CH 7 negative)
6	CH 3 H (CH 3 positive)	16	CH 8 H (CH 8 positive)
7	CH 3 L (CH 3 negative)	17	CH 8 L (CH 8 negative)
8	CH 4 H (CH 4 positive)	18	N.C. (No connection)
9	CH 4 L (CH 4 negative)		
10	CH 5 H (CH 5 positive)		

### Connecting the signal wires



#### CAUTION

- Do not apply a voltage exceeding the following levels, as it may damage the module.  
Maximum allowable input voltage:  $\pm 60$  V(DC+ACpeak)  
(Overvoltage Category/Measurement Category: CAT II)  
Maximum common mode voltage: 300 VACrms or  $\pm 300$  VDC between the ground and all input terminals  
Maximum voltage between channels: 100 VACrms or  $\pm 100$  VDC between any two terminals of different channels
- Do not connect anything to the N.C. (no connection) terminals. Accidentally applying signal to them may damage the module.



#### WARNING

- Make sure that the conducting parts of the input signal wire are not showing from the opening (insertion point) of the terminal block. It can lead to electric shock.

### Note

When the input voltage exceeds 7 V when making measurements in the  $\pm 50$  mV to  $\pm 5$  V range, the input impedance drops from approx. 1 M $\Omega$  (normal) to approx. 7 k $\Omega$ .

## 2.2 Connecting the Input Signal Wire

---

The terminal block can be removed from the module by loosening the two attachment screws as shown in the following figure. When removing or attaching the terminal block, make sure to turn OFF the standby power switch on the measuring station.

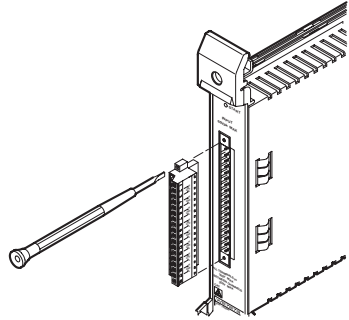

When connecting the input signal wire to the clamp type terminal, loosen the screw holding down the clamp, insert the input signal wire into the opening, and then tighten the screw.

Recommended length of the stripped portion of the input signal wire: 10 mm  
Thickness of the input signal wire (for twisted wire): 0.2 to 2.5 mm<sup>2</sup> (AWG24 to 12)

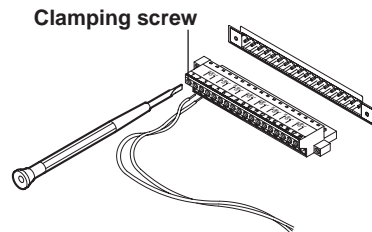

## 3.1 Troubleshooting

- If servicing is necessary, or if the instrument is not operating correctly after performing the following corrective actions, contact your nearest YOKOGAWA dealer.
- To verify that the module is operating correctly, perform the self test as described on the next page.

Problem	Probable Cause/Corrective Action	Reference
Module does not operate.	Check to see that the module is installed correctly into the station. Also, install the module into another slot, and check whether it will operate there. If it operates in the other slot, the measuring station is likely to have malfunctioned. If the module is installed correctly and does not operate, the connector might be bad or the IC may have malfunctioned. In either case, contact your nearest YOKOGAWA dealer to have it repaired.	2-1, *
Waveform data cannot be acquired.	Check to see that the input signal wires are connected properly. Also check the terminal block connection.	2-3, 2-4
Noise enters the input signal.	If the signal line and the AC power supply line are close to each other, move them apart. Also make sure that the signal line is away from the noise source. Change to a shielded signal wire if you are not already using one.	—
Measured values are not correct.	Check whether the ambient temperature and humidity are within the allowed ranges. If you did not allow a warm-up time of 30 minutes, try measuring again after the warm-up time has passed. Check that the output impedance of the signal source is less than the maximum source resistance that is allowed.	4-4 4-1
Triggering does not work.	Check whether the trigger setting is adequate for the input source in the trigger operation panel. If you are using the bus trigger signal, verify that the settings are correct in the trigger source/time base/arming setting dialog box of the WE7000 Control Software.	1-2, 1-7 *
The waveform monitor is not displayed.	Check that the [Waveform monitor ON/OFF] button, that is located to the right of the [Start] button on the operation panel, is turned ON.	1-2

\* See the WE7000 User's Manual (IM 707001-01E).

## 3.2 Self Test

If you believe that the module is not operating correctly, perform the self test according to the following procedure with connected to the input terminals of the module being tested and the external trigger input terminal/external I/O connector of the measuring station.

### Executing Self Test

1. Select [Self Test] from the [System] menu of the WE7000 Control Software.

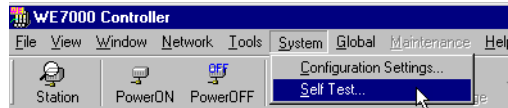

2. In the [Self Test] dialog box that appears, select the station name and enter the slot number corresponding to the module, and click the [Execute] button.

“Executing...” is displayed in the [Result] display box.

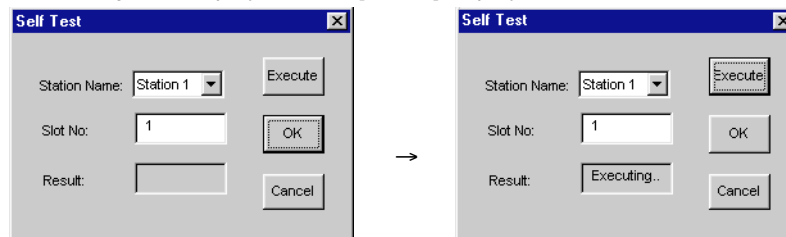

### Verifying Test Results

If a value other than “0” is displayed in the “Result” display box of the “Self Test” dialog box, the module is probably malfunctioning. Please contact your nearest YOKOGAWA dealer.



---

## 3.3 Maintenance

### Maintenance of Parts

There are no parts in this module that require periodic replacement.

### Calibration

We recommend that you calibrate the Measurement module once a year to assure its measurement accuracy. Please contact your nearest YOKOGAWA dealer to have the module calibrated.

## 4.1 Performance Specifications

### Number of Input Channels

8

### Input Format

Floating unbalanced input, isolation between channels and between the input and ground

### Connector Type

Clamp terminal (terminal block is detachable)

### Input Coupling

DC/AC

### Measurement Range

 $\pm 50$  mV to  $\pm 50$  V (1-2-5 steps)

### A/D Resolution

16 bits (includes the sign)

### Input Impedance

Approx. 1 M $\Omega$ 

### Maximum Source Resistance

100  $\Omega$  or less

### Frequency Characteristics (–1.5 dB attenuation point, during filter OFF)

During AC coupling: 10 Hz to 40 kHz (Typical value\*)

During DC coupling: DC to 40 kHz (Typical value\*)

### Input Filter

OFF/5 kHz/500 Hz/50 Hz (–3 dB attenuation point) (Typical value\*)

### DC Accuracy (value measured at an ambient temperature of $23\pm 5^\circ\text{C}$ , ambient humidity of $50\pm 10\%$ RH, after the warm-up time has passed)

Measurement Range	Accuracy	Temperature Coefficient (at $5\text{-}18^\circ\text{C}$ or $28\text{-}40^\circ\text{C}$ )
$\pm 50$ mV	$\pm(0.15\%$ of rdg + 0.5 mV)	$\pm(30$ ppm + 20 $\mu\text{V}/^\circ\text{C}$
$\pm 100$ mV	$\pm(0.15\%$ of rdg + 0.5 mV)	$\pm(30$ ppm + 25 $\mu\text{V}/^\circ\text{C}$
$\pm 200$ mV	$\pm(0.15\%$ of rdg + 0.5 mV)	$\pm(30$ ppm + 30 $\mu\text{V}/^\circ\text{C}$
$\pm 500$ mV	$\pm(0.05\%$ of rdg + 0.5 mV)	$\pm(25$ ppm + 30 $\mu\text{V}/^\circ\text{C}$
$\pm 1$ V	$\pm(0.05\%$ of rdg + 0.7 mV)	$\pm(25$ ppm + 30 $\mu\text{V}/^\circ\text{C}$
$\pm 2$ V	$\pm(0.05\%$ of rdg + 1.4 mV)	$\pm(25$ ppm + 50 $\mu\text{V}/^\circ\text{C}$
$\pm 5$ V	$\pm(0.05\%$ of rdg + 3.5 mV)	$\pm(25$ ppm + 0.1 mV)/ $^\circ\text{C}$
$\pm 10$ V	$\pm(0.05\%$ of rdg + 7 mV)	$\pm(45$ ppm + 0.5 mV)/ $^\circ\text{C}$
$\pm 20$ V	$\pm(0.05\%$ of rdg + 14 mV)	$\pm(45$ ppm + 0.7 mV)/ $^\circ\text{C}$
$\pm 50$ V	$\pm(0.05\%$ of rdg + 35 mV)	$\pm(45$ ppm + 1 mV)/ $^\circ\text{C}$

### Residual Noise (With filter OFF and input terminals shorted)

 $\pm 400$   $\mu\text{V}$  or  $\pm 0.04\%$  of (upper limit of range – lower limit of range), whichever is greater (Typical value\*)

### Common Mode Rejection Ratio (With filter OFF at 50/60 Hz)

 $\pm 50$  mV to  $\pm 5$  V range: 100 dB or higher (Typical value\*) $\pm 10$  V to  $\pm 50$  V range: 80 dB or higher (Typical value\*)

### Acquisition Method

Trigger, free run, gate (level), gate (edge)

### Memory Length of Acquisition Memory

8 Mword

### Memory Partition (Partition Possible Only When Trigger Mode Is Selected)

Select from 1/2/4/8/16/32/64/128/256 partitions

### Maximum Record Length

1 Mword/CH (for 5 CH to 8 CH measurement), 2 Mword/CH (for 3 CH/4 CH measurement), 4 Mword/CH (for 2 CH measurement), 8 Mword/CH (for 1 CH measurement)

## 4.1 Performance Specifications

---

### Time Base Source

Module's internal clock, or the time base signal (CMNCLK) of the measuring station (WE bus)

### Maximum Sampling Rate

100 kS/s

### Internal Time Base

10  $\mu$ s to 10 s (1  $\mu$ s step)

### Trigger Base Accuracy

Same as the reference clock of the measuring station ( $\pm$ 100 ppm for 707001/707002)

### Trigger Source

Input signal (includes input signals of other isolated digitizer modules that are linked), or the bus trigger (BUSTRG1/BUSTRG1) signal of the measuring station

### Bus Trigger Signal (BUSTRG1/BUSTRG2) Output Source

Able to output the trigger detected from the input signal

### Trigger Level

Resolution

Measurement Range	Resolution
$\pm$ 50 mV	0.1 mV
$\pm$ 100 mV	1 mV
$\pm$ 200 mV	1 mV
$\pm$ 500 mV	1 mV
$\pm$ 1 V	10 mV
$\pm$ 2 V	10 mV
$\pm$ 5 V	10 mV
$\pm$ 10 V	100 mV
$\pm$ 20 V	100 mV
$\pm$ 50 V	100 mV

Hysteresis width: 0.5% of (upper limit of range – lower limit of range) (Typical value\*)

Measurement accuracy: 1% of  $\pm$ (upper limit of range – lower limit of range)

### Trigger Type

Edge trigger, state trigger, combination trigger (AND/OR of the input signals)

### Pre-trigger Amount (Selectable Only When Trigger Mode Is Selected)

Set in the range from 0 to (the record length – 2)

### Skew between Channels (within the same module)

50 ns (Typical value\*)

### Skew between Modules (when modules of the same type are linked)

$[20 \times (N-1) + 50]$  ns + skew between channels within the same module

(between the 1st and the Nth module when WE7273s are linked, typical value\*)

\* Typical value represents a typical or average value. It is not strictly guaranteed.

---

## 4.2 Default Values (Factory Default Settings)

On (measurement ON/OFF): On (CH1 to CH8)  
Coupling (input coupling): DC (CH1 to CH8)  
Range (measurement range): 50 V (CH1 to CH8)  
Acquisition Mode: Triggered  
Sampling Interval: 10 us  
Memory Partition: 1  
Record Length: 1000  
No. of Acquisitions : 1  
Filter (input filter): Off  
Time Base: Internal  
CH Mode (number of measurement channels): 8CH  
Trig Type: Rise (CH1), Off (CH2 to CH8)  
Trig High (trigger level): 0 V  
Trig Source: Internal  
Trig Combination: OR  
Pretrigger: 0 samples  
Hold Off: 1000 samples  
Overlapped Acquisition (overlapped acquisition permission): Off  
Repeat (continuous measurements): On

---

## 4.3 General Specifications

### Safety Standard

Complies with CSA C22.2 No. 1010.1 and EN61010-1, conforms to JIS C1010-1

- Overvoltage Category CAT II\*<sup>1</sup>
- Measurement Category CAT II\*<sup>2</sup>
- Pollution Degree 2\*<sup>3</sup>

\*1 Overvoltage Categories define transient overvoltage levels, including impulse withstand voltage levels.

Overvoltage Category II: Applies to equipment supplied with electricity from fixed installations like a distribution board.

\*2 Measurement Category describes a number which defines transient stresses from the circuit to which they are connected during measurement or test. It implies the regulation for impulse withstand voltage. Measurement Category is applied to the measuring circuit.

Measurement Category II: For measurements performed on circuits directly connected to the low voltage installation.

NOTE: Examples are measurements on household appliances, portable tools and similar equipment.

\*3 Pollution Degree: Applies to the degree of adhesion of a solid, liquid, or gas which deteriorates withstand voltage or surface resistivity.

Pollution Degree 1: Applies to closed atmospheres (with no, or only dry, non-conductive pollution).

Pollution Degree 2: Applies to normal indoor atmospheres (with only non-conductive pollution).

### EMC Standards

#### Emission

Complying Standard

EN55011 Group 1 Class A

This product is a Class A (for industrial environment) product. Operation of this product in a residential area may cause radio interference in which case the user is required to correct the interference.

#### Immunity

Complying Standard

EN61326 Industrial Environment

Influence in the immunity environment

Noise increase  $\leq \pm 5\%$  of (upper limit of range – lower limit of range)

Maximum Measuring Input Cable Length

30 m

### Standard Operating Conditions

Ambient temperature: 23°C  $\pm 5^\circ\text{C}$

Ambient humidity: 50 $\pm$ 10% RH

Supply voltage/frequency error: Within 1% of rating

After warm-up time has passed

### Warm-up Time

At least 30 minutes

### Maximum Allowable Input Voltage

$\pm 60$  V(DC + ACpeak) (Overvoltage Category/measurement Category: CAT II)

### Maximum Common Mode Voltage (between Ground and all Input Terminals)

$\pm 300$  VACrms or  $\pm 300$  VDC (Overvoltage Category/measurement Category: CAT II)

### Maximum Voltage Across Channels

**Between any two terminals of different channels in the same module**

$\pm 100$  VACrms or  $\pm 100$  VDC (Overvoltage category/measurement category: CAT II)

**Between any two terminals of channels on different modules**

$\pm 300$  VACrms or  $\pm 300$  VDC (Overvoltage category/measurement category: CAT II)

**Withstand Voltage****Between ground and input terminal**

1500 Vrms at 60 Hz for one minute

**Between channels in the same module**

800 Vrms at 60 Hz for one minute

**Between channels of different modules**

2300 Vrms at 60 Hz for one minute

**Insulation Resistance (between the Input Terminal and Ground and between Each Channel)**Between input terminal and ground and between channels: 500 VDC, 10 M $\Omega$  or more**Operating Conditions**

Same as those of the measuring station

**Storage Conditions**

Temperature: -20 to 60°C

Humidity: 20 to 80% RH (no condensation)

**Power Consumption**20 VA (Typical value\*<sup>3</sup> at 100 V/50 Hz)**Weight**

Approx. 0.9 kg

**External Dimensions**

Approx. 33(W) × 243(H) × 232(D)mm (projections excluded)

**Number of Used Slots**

1

**Standard Accessories**

Terminal block (1) (attached to the input connector at the time of shipment), User's Manual (1)

**Optional Accessories**

Terminal block (Model: B9953FE)

\* Typical value represents a typical or average value. It is not strictly guaranteed.

## 4.4 Dimensional Drawings

Unit: mm

### 8-CH, 100 kS/s Isolated Digitizer Module

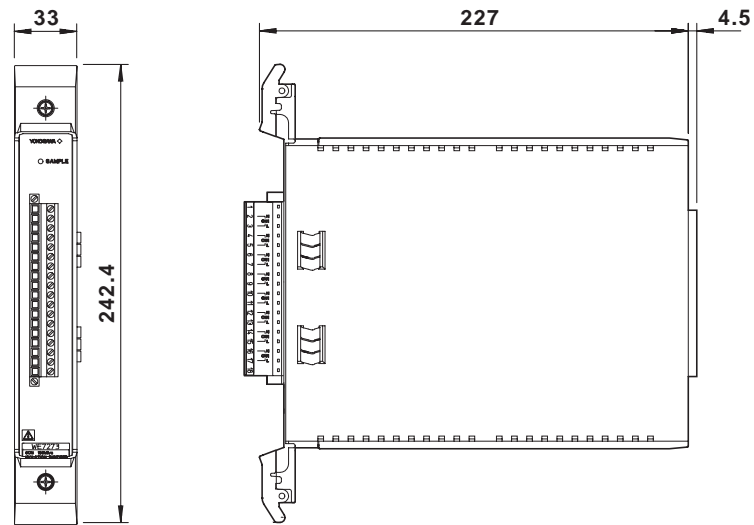

If not specified, the tolerance is  $\pm 3\%$ . However, in cases of less than 10 mm, the tolerance is  $\pm 0.3$  mm.

# Index

## Symbols

*.csv .....	1-8
*.wvf .....	1-8

## A

Acquisition method, selecting .....	1-3
Acquisition Mode .....	1-3
Acquisitions, number of .....	1-5
AND trigger .....	1-7
Arming .....	1-11

## B

Both .....	1-7
Bus trigger signal, input/output of .....	1-10
BUSTRG .....	1-7

## C

CH Mode .....	1-6
Combination .....	1-7
Cyclic .....	1-8

## E

Edge trigger .....	1-7
--------------------	-----

## F

Fall .....	1-7
File conversion .....	1-8
File number limit .....	1-8
Filter 1 kHz .....	1-6
Free Run .....	1-3

## G

Gate(Edge) .....	1-4
Gate(Level) .....	1-4

## H

High .....	1-7
Hold Off .....	1-7

## I

Input connector .....	1-12
Input filter, turning ON/OFF .....	1-6
Input terminal block .....	2-3
Internal .....	1-7

## L

Low .....	1-7
-----------	-----

## M

Measurement channels, number of .....	1-6
Measurement range, selecting .....	1-3
Memory Partition .....	1-4
MODEL .....	2
Module, installation of .....	2-1

## N

NO .....	2
No. of Acquisitions .....	1-5

## O

OR trigger .....	1-7
------------------	-----

## P

Package .....	2
Pretrigger .....	1-7

## R

Range .....	1-3
Record Length .....	1-5
Repeat .....	1-3
Rise .....	1-7

## S

Sampling indicator .....	1-12
Sampling Interval .....	1-4
Scale conversion .....	1-9
Self test .....	3-2
Source .....	1-7
Start timing of measurement, controlling .....	1-11
State trigger .....	1-7

## T

Time Base .....	1-6
Trig Type .....	1-7
Trigger combination, selecting .....	1-7
Trigger hold off, setting .....	1-7
Trigger level, setting .....	1-7
Trigger mode .....	1-3
Trigger source, selecting .....	1-7
Trigger type, selecting .....	1-7
Triggered .....	1-3
Troubleshooting .....	3-1

## W

Waveform data, automatic saving of .....	1-8
------------------------------------------	-----